



TMAC 2023 Final: Open Class Regulations

Updates as of May 30, 2023

- CNC and Anodized rollers are not allowed.
- Batteries should be bought from the organizer; Fujitsu Alkaline Premium. Battery voltage should be less than 1.64V.

【1】 Machines

1. Usable Machine Types

Only Laser Mini 4WD, Mini 4WD REV, Mini 4WD PRO, Racing Mini 4WD, Super Mini 4WD, Fully-Cowled Mini 4WD, Aero Mini 4WD, Mighty Mini 4WD, R/C Mini 4WD, and Truckin' Mini 4WD machines are permitted. Further restrictions on machine types may be possible depending on the race event or race class.

2. Machine Assembly

All machines must be four-wheel drive. Modifications that result in rear-wheel or front-wheel drive are prohibited. Bodies should have stickers applied or be painted, and must be securely attached to the chassis. Please be warned that bodies which are particularly small, or those which it is difficult to check are painted or have stickers applied, may be prohibited. Home-made bodies are prohibited. The following are not recognized as bodies: cut-off sections from clear bodies, etc.; wing only. All machines must go through car inspection and machines that do not pass inspection cannot participate in the race. As a general rule, machines must be assembled by the racer. Some exceptions may be applied. Please ask Race Officials.

3. Machine Measuring System

All machines must have a 4WD setup and will be subject to the same measuring system as shown below.

Width	Length	Height	Ground Clearance	Tire Diameter	Tire Width	Weight	Rollers	Drivetrain	Gears
									
Under 105mm Including all attached parts	Under 165mm Including all attached parts	Under 70mm Including wing	Over 1mm From flat surface	22-35mm Both front & rear	8-26mm Both front & rear	Over 90g w/ motor & batteries	Unlimited amount	Must be 4WD	Must be installed according to the set gear ratio

- Maximum Car Width: Under 105mm
- Overall Car Height: Under 70mm
- Overall Car Length: Under 165mm
- Minimum Ground Clearance: At least 1mm

- Minimum Car Weight (including batteries and motor): At least 90g
- Front and Rear Tires: Diameter: 22-35mm, Width: 8-26mm (Note that tires must be attached.)
- Rollers: There is no limit on the amount of rollers that can be used.
- Mass Dampers: The installation positions of rotating mass dampers are no longer limited.

When adding parts*¹ to the car, please note the zone restrictions below.

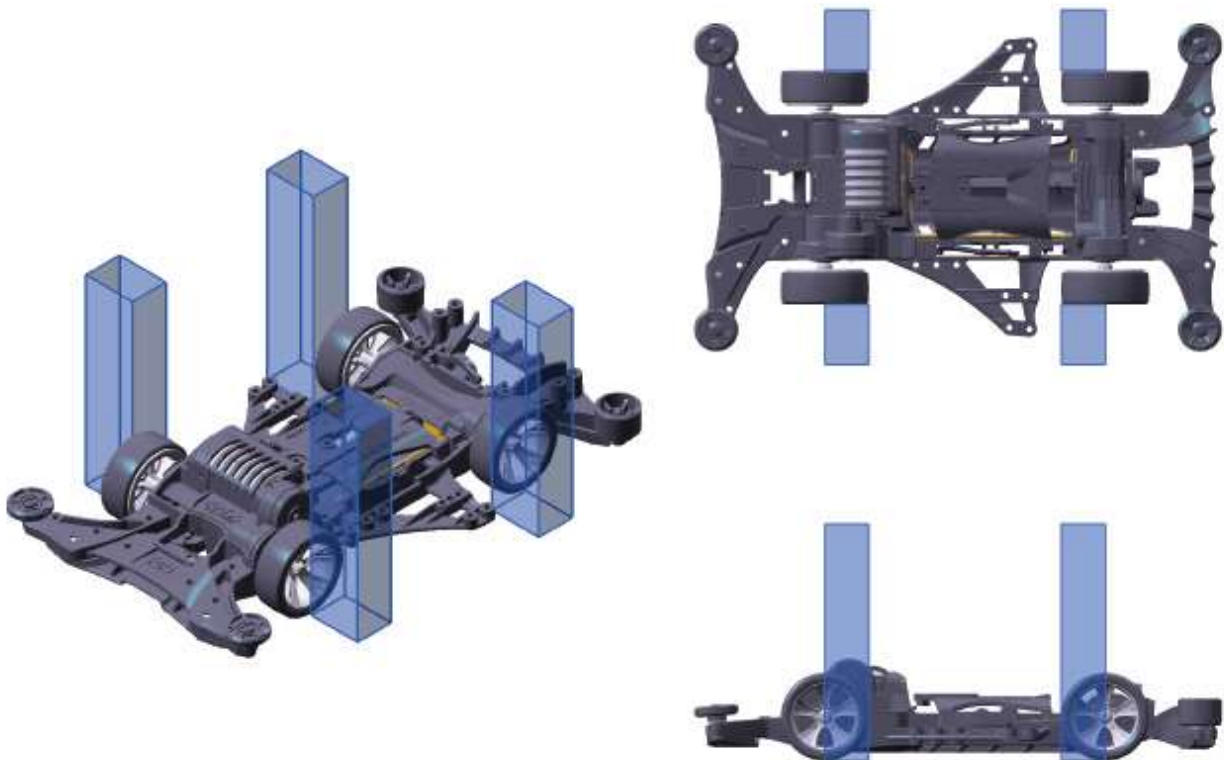

- Parts may not be installed outside of the front tire, between the center of the front wheel and its rear edge. *²
- Parts may not be installed outside of the rear tire, between the center of the rear wheel and its front edge. *²

*¹ Bodies are the exception to this rule.

Additionally, there are no restrictions on parts such as hi-mount rollers that are attached exclusively to the body if they are directly above the wheel axle.

*² A tire's "outside" is defined as its outermost edge.

See image above for a visual representation of the restricted areas.



4. Motor

Machines may use the kit-included normal motor, Rev-Tuned Motor, Torque-Tuned Motor, Atomic-Tuned Motor, Sprint-Dash Motor, Power-Dash Motor, Hyper-Dash 2 Motor, Hyper Mini Motor, Light-Dash Motor, Hyper-Dash 3 Motor, Rev-Tuned 2 Motor, Torque-Tuned 2 Motor and Atomic-Tuned 2 Motor. Mini 4WD PRO machines may only use the kit-included normal motor or motors designed for use with the Mini 4WD PRO series.

1. Depending on the race event, other Tamiya motors may be permitted.
2. For speed-limited race events or classes, if your speed exceeds the allowed limit, even the above motors may not be installed.
3. Disassembling the motor to change the number of coils and other such illegal modifications is prohibited.
4. If there are indications that the motor cap has been detached, it will be judged as being illegally modified.

5. Batteries

Only Fujitsu-branded alkaline batteries are permitted. If a battery has no label or appears to be damaged in any way, it will not be accepted for safety reasons. Please note that some events may have different rules regarding which types or brands of batteries can be used.

6. Modifications

Please follow the guidelines below when modifying your car. Also note that for modifications not listed, race officials will have the final absolute authority to grant or deny their use.

1. Chassis modifications are limited to cutting away plastic material or cutting holes out of the stock chassis. Homemade chassis and homemade parts are prohibited.
2. Parts used for modification are limited to Tamiya Mini 4WD, R/C Mini 4WD, and Dangun Racer parts only.
3. Part modifications are limited to cutting away the material or making holes in the stock part.

[NOTE] Original part shape must be clearly identifiable.

In the following cases, it will be considered that the original part shape is not identifiable:

- ✘ **Modifications to the part shape on carbon plates, FRP plates or metal parts (including modifications to shaft, pin or roller shape).**
- ✘ **Using rollers and parts in prohibited combinations (putting plastic rings on rollers that do not use them; using plastic ring rollers without ring).**
- ✘ **Attaching HG aluminum setting boards, setting gauges and pinion pullers to the car.**



In the following cases, it will be considered that the original part shape is identifiable:

- ※Modifications to parts that keep the original part shape, such as simply cutting away the material, or enlarging or adding parts attachment holes.
 - ※Opening holes or painting on the top side of the rollers.
 - ※Modifying or cutting tire material (changing the material properties of the tire surface is prohibited. Combining different sizes or materials of tires is allowed. However, please make sure that they do not fall apart during running).
 - ※Using motor parts is allowed (motor disassembly is not recommended).
4. Gear modifications are limited to making holes or shaving away material to reduce weight and installing ball bearings. All running gears must be installed according to the set gear ratios.
 5. Only kit-included battery terminals or Grade-Up Part battery terminals, installed according to the instruction manuals, may be used. Soldering or double-plated terminals are prohibited.
 6. Modifications that cause damage to the track, cause injury to any person, or release grease and/or other substances onto the track are all prohibited.
 7. Modifications to the tire's shape are allowed if they comply with the Car Measuring System outlined above. However, changing the material properties of the tire surface is prohibited.

【2】 Race Courses

For courses which satisfy the below specifications and are sanctioned by Tamiya, times recorded during races will be officially recognized. All times recorded on original courses that do not meet these requirements will be considered unofficial.

- Individual Lane Width: 115mm (measured on a straight section)
- Course Wall Height: 50mm (measured from road surface)
- Adjusting the height and lane width of lane change sections, bank turn sections, etc. for smoother racing operations is permitted.

【3】 For Competitions at Official Race Courses

1. The start of the race will be indicated by a signal from a Tamiya race official or a starting signal system. Racers will switch on their cars, hold them in the air with one hand, and drop them vertically into their assigned lane at the start signal. Throwing or pushing the car forward is prohibited.
2. A racer will immediately retire from a race if their car leaves the track, flips over, jumps into another lane, or if their car's body detaches during the race.



3. If race officials determine that a racer's car is blocking the progress of faster machines, the racer will be required to retire.
4. A car's race is completed when it reaches the finish line.
5. Qualifying and Final positions are determined by either the race finishing order or Time Attack time.

【4】 Car Inspection

1. All racers must have their car inspected by race officials before the race. If any part of the car is determined to be against race regulations, the racer must make the necessary changes in order to participate in the race.
2. From the time the car passes the car inspection to when the race begins, the car's settings must not be changed and no modifications can be made.
3. In addition to the pre-race car inspection, other car inspections may occur at any time during the race day at the race official's discretion. If the car is found to be in violation of the race regulations at any of these inspections, the racer's race results up to that point will be disqualified and the racer must make necessary changes in order to participate in subsequent races.
4. If a machine does not pass car inspection, and cannot be made race-legal, the participant can still take part in the Qualifying rounds for their own benefit, but their times will not be recorded.

【5】 Disqualification

If any of the following situations occur, race officials will, at their discretion, have absolute authority to disqualify any racer. Please take care to remember the common manners for a Mini 4WD race to avoid any problems.

1. A racer's car is determined to have modifications that will cause physical harm to other racers, other cars, or the race track.
2. A racer's car is determined to have modifications that are designed to deliberately obstruct other cars.
3. A racer deliberately puts grease or other substances onto the track to affect track surface conditions.
4. A racer is determined to have modified their car after it had passed the car inspection.
5. A racer is determined to have deliberately touched the track or cars to impede other racers' race progress.
6. A racer does not follow the instructions of race officials or otherwise impedes the operations of



the race track.

7. A racer has a false start, or is determined to have thrown or pushed their car forward at the start of a race.
8. A racer is determined to have acted against the spirit of fair play or caused distress to other participants.

【6】 Race Operations

1. Participants may raise objections to the race officials. However, these objections must be made before the next race begins.
2. Race officials reserve the right to announce the use of special regulations at any time.

【7】 Participant Restrictions

1. Please be aware that some races have age limitations, so it may be that some participants cannot take part in certain classes or races.
2. Except for endurance races, it is against regulations to have more than 2 racers using the same car.